

**MODEL 517 3- POINT MOUNT LOGSPLITTER POWERTEK**

**Model 517 3- Point Log Splitter  
Operation & Maintenance Manual**

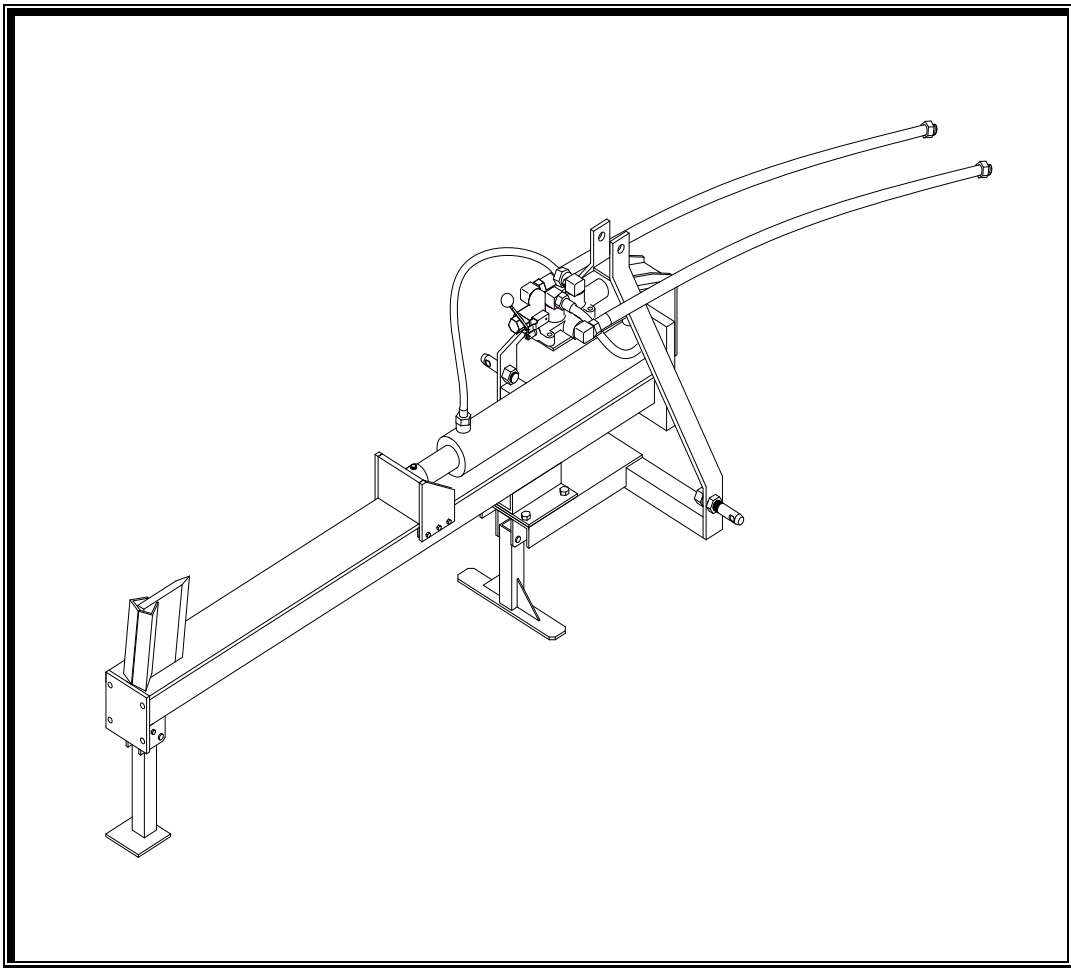

**PowerTek Inc.  
P.O. Box 3  
Lebanon, In. 46052  
1-877-769-7835**

11-1-07

<b>TABLE OF CONTENTS</b>	<b>POWERTEK</b>
--------------------------	-----------------

- ASSEMBLY INSTRUCTIONS.....2, 3**
- DO BE CAREFUL.....4**
- PARTS BREAKDOWN.....5**
- PARTS LIST.....6**
- GETTING STARTED.....7**
  - GENERAL DESCRIPTION.....7
  - LOG SPLITTER PREPERATION.....7
- SAFETY.....8-10**
  - TRAINING.....8
  - PREPARATION.....9
  - OPERATION.....9
  
- LUBRICATION & OIL.....10**
- MAINTENANCE SCHEDULE.....10**
- CONTROLS.....11**
- OWNERS INFORMATION.....12**
- WARRANTY.....13-14**



**PowerTek Inc.- LOG SPLITTERS  
Shipped Partially Assembled**

**OWNER/OPERATOR'S INFORMATION FOR POWERTEK  
LOG SPLITTER RESPONSIBILITY**

**IT IS THE OPERATORS RESPONSIBILITY TO:**

1. Carefully read and understand the entire Operation & Maintenance Manual along with the Assembly Instructions.
2. Be certain that all assembly procedures are followed as described in the following Assembly Instructions.
3. Operate the log splitter according to the safe operating procedures as spelled out in the Operation & Maintenance Manual and these Assembly Instructions.
4. Perform all required maintenance as directed in the Operation & Maintenance Manual and these Assembly Instructions.

**UNPACKING LOOSE PARTS:**

Using care, remove the cover and sides from the pallet. The log splitter assemblies and parts are secured with bands. Carefully cut the bands. Remove all parts from the skid and layout in a clear unobstructed working area. Use the parts list below to assure all parts are accounted for. Do not discard packing material until assembly is complete to insure that no required parts are accidentally discarded.

Tools required: Adjustable wrench and socket set.

**ASSEMBLY:**

This unit must be assembled before use. Care must be taken in assembly to insure the proper Functioning and reliability of the unit. Assembly must be done in a dry and clean area.

1. Rotate rear kickstand down and pin in place.
2. Roll the beam up and place on block near middle.
3. Remove nuts holding cylinder in place.
4. Slide 3-Point Mount over beam and bolt in place on underside of beam
5. Replace cylinder nuts, capturing mount plate on front of 3-Point mount.
6. Pin front kick stand in place,
7. Attach hydraulic hoses from cylinder to hydraulic control valve.  
(See Fig 1)
8. Attach unit to tractor.
9. Attach hydraulic hoses from hydraulic control valve to tractor.

**Fig. 1**

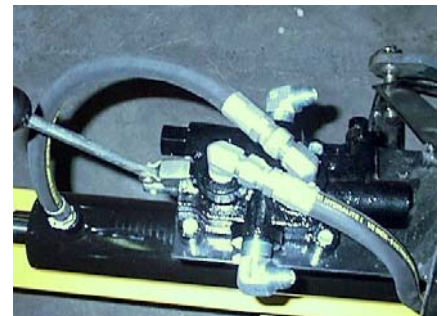

**BEFORE EACH USE DO THE FOLLOWING:**

1. Make sure all bolts, fittings, and hoses are tight. If fittings are not tight, log splitter will not function properly.
2. Make sure you have read the all safety and start up procedures in the Operation and Maintenance Manual.
3. Check for oil leaks on initial start-up. Repair any hydraulic lines, as necessary.



DO NOT OPERATE THIS LOG SPLITTER UNTIL YOU HAVE AND UNDERSTAND THE OPERATING AND SAFETY INSTRUCTIONS. FAILURE TO READ AND FOLLOW OPERATING INSTRUCTIONS CAN RESULT IN SERIOUS INJURY OR DEATH TO YOURSELF AND/OR OTHERS

**DO**

- DO MAKE SURE THAT ANYONE WHO OPERATES THIS SPLITTER READS AND UNDERSTANDS ALL OPERATING INSTRUCTIONS AS TO ITS PROPER USE AND OPERATION AS WELL AS ALL SAFETY INSTRUCTIONS.
- DO KEEP YOUR WORK AREA CLEAN. DON'T LEAVE WOOD LAYING AROUND THAT YOU COULD STUMBLE OVER.
- DO KEEP HANDS AND FEET CLEAR OF SPLITTER BLADE AND OUT OF SPLITTER AREA WHILE UNIT IS IN OPERATION.
- DO WIPE UP SPILLED GAS RIGHT AWAY FROM THE ENGINE AND LOG SPLITTER BEFORE STARTING THE ENGINE.
- DO CHECK ENGINE OIL LEVEL AND HYDRAULIC OIL LEVEL BEFORE STARTING THE SPLITTER.
- DO USE THE UNIT ONLY TO SPLIT FIREWOOD LOGS. USE OF THIS UNIT FOR ANY OTHER PURPOSE SHALL VOID THE WARRANTY.
- DO WEAR EYE PROTECTION AND PROTECTIVE CLOTHING, INCLUDING SAFETY SHOES AT ALL TIMES WHILE LOG SPLITTER IS IN OPERATION TO AVOID ANY HAZARD FROM FLYING WOOD.
- DO KEEP CHILDREN AND PETS AWAY FROM THE WORK AREA WHILE YOU ARE OPERATING THE LOG SPLITTER.
- DO SHUT OFF THE ENGINE IF YOU LEAVE THE LOG SPLITTER, EVEN FOR A SHORT PERIOD OF TIME.
- DO OPERATE LOG SPLITTER ON LEVEL SURFACE BLOCK WHEELS TO PREVENT UNINTENDED MOVEMENT.
- DO LET GO OF THE CONTROL LEVER AFTER IT IS PUSHED FORWARD. THE RAM WILL RETURN AUTOMATICALLY AT THE END OF THE STROKE. THE RAM CAN ALSO BE STOPPED AT ANY POINT IN ITS TRAVEL AND RETURNED.
- DO REMOVE BOTH HANDS FROM LOG BEFORE ACTIVATING CONTROL LEVER.
- DO BE SURE THE SPLITTER IS KEPT IN SOUND MECHANICAL CONDITION. PROPER CARE, MAINTENANCE AND FOLLOWING ALL OPERATING AND SAFETY INSTRUCTIONS WILL PROVIDE YOU WITH MANY YEARS OF TROUBLE-FREE AND SAFE OPERATION.

**DO NOT**

- DO NOT ALLOW ANYONE TO OPERATE THE LOG SPLITTER UNTIL THEY HAVE READ AND UNDERSTAND THE OPERATING INSTRUCTIONS AND SAFETY INSTRUCTIONS. DO NOT ALLOW ANYONE UNDER 18 YEARS OF AGE TO OPERATE THE LOG SPLITTER
- DO NOT OPERATE THE LOG SPLITTER IN THE VICINITY OR NEAR CHILDREN OR PETS.
- DO NOT WEAR JEWELRY, LOOSE-FITTING CLOTHING OR CLOTHING WITH DRAWSTRINGS WHEN OPERATING THE LOG SPLITTER, AS SUCH JEWELRY OR CLOTHING MAY BECOME ENTANGLED IN MOVING PARTS OF LOG SPLITTER.
- DO NOT OPERATE RAM CONTROL LEVER IN ANY WAY OTHER THAN BY HAND.
- DO NOT LEAVE THE LOG SPLITTER UNATTENDED WITH THE ENGINE RUNNING.
- DO NOT OPERATE THE LOG SPLITTER BEYOND THE CAPABILITIES AS OUTLINED IN THE OWNERS MANUAL AND OPERATING INSTRUCTIONS.
- DO NOT STEP OVER THE LOG SPLITTER WHEN RUNNING. WALK AROUND THE LOG SPLITTER TO GET TO THE OTHER SIDE.
- DO NOT STRADDLE THE LOG SPLITTER WHEN OPERATING.
- DO NOT LET ANYONE STAND NEAR THE WEDGE WHEN SPLITTING WOOD, AS FLYING WOOD MAY BE HAZARDOUS.
- DO NOT STAND ON SLIPPERY, WET, MUDDY OR ICY SURFACES WHEN OPERATING THE LOG SPLITTER. OPERATE ONLY WHEN OPERATOR ZONE IS CLEAR FOR SAFE, SECURE FOOTING.
- DO NOT OPERATE THE LOG SPLITTER INSIDE A BUILDING OR CLOSED IN AREA THAT DOES NOT HAVE ADEQUATE VENTILATION.
- DO NOT REFUEL WHILE ENGINE IS ON OR HOT, WHILE OPERATOR IS SMOKING OR WHILE UNIT IS NEAR OPEN FLAME.
- DO NOT OPERATE THE LOG SPLITTER IF IT NEEDS REPAIRS OR MAINTENANCE.
- DO NOT MAKE ANY MODIFICATIONS, ALTERATIONS OR CHANGES TO THE ORIGINAL CONFIGURATION OF THE LOG SPLITTER. THIS MAY CAUSE INJURY AND SHALL VOID THE WARRANTY.
- DO NOT EVER LOAD A LOG BY HOLDING ONTO BOTH ENDS OF THE LOG.
- DO NOT PLACE YOUR HANDS BETWEEN THE RAM AND THE LOG, BETWEEN THE LOG AND THE WEDGE, OR BETWEEN TWO PIECES OF LOG ON THE FRAME. SEE OWNERS MANUAL FOR PROPER LOADING PROCEDURES.
- DO NOT SERVICE OR REPAIR LOG SPLITTER WITHOUT REMOVING THE SPARK PLUG WIRE.
- DO NOT ALLOW ANYONE EXCEPT THE OPERATOR WITHIN 10 FEET OF LOG SPLITTER DURING OPERATION.
- DO NOT OPERATE UNIT WITH HYDRAULIC FLUID LEAK. CHECK HYDRAULIC LINE BEFORE OPERATING LOG SPLITTER, AND REPAIR OR REPLACE AS NECESSARY.

**DO  
BE CAREFUL  
SAFETY FIRST !!!**

# 3-Point Mount Splitter      Parts Breakdown

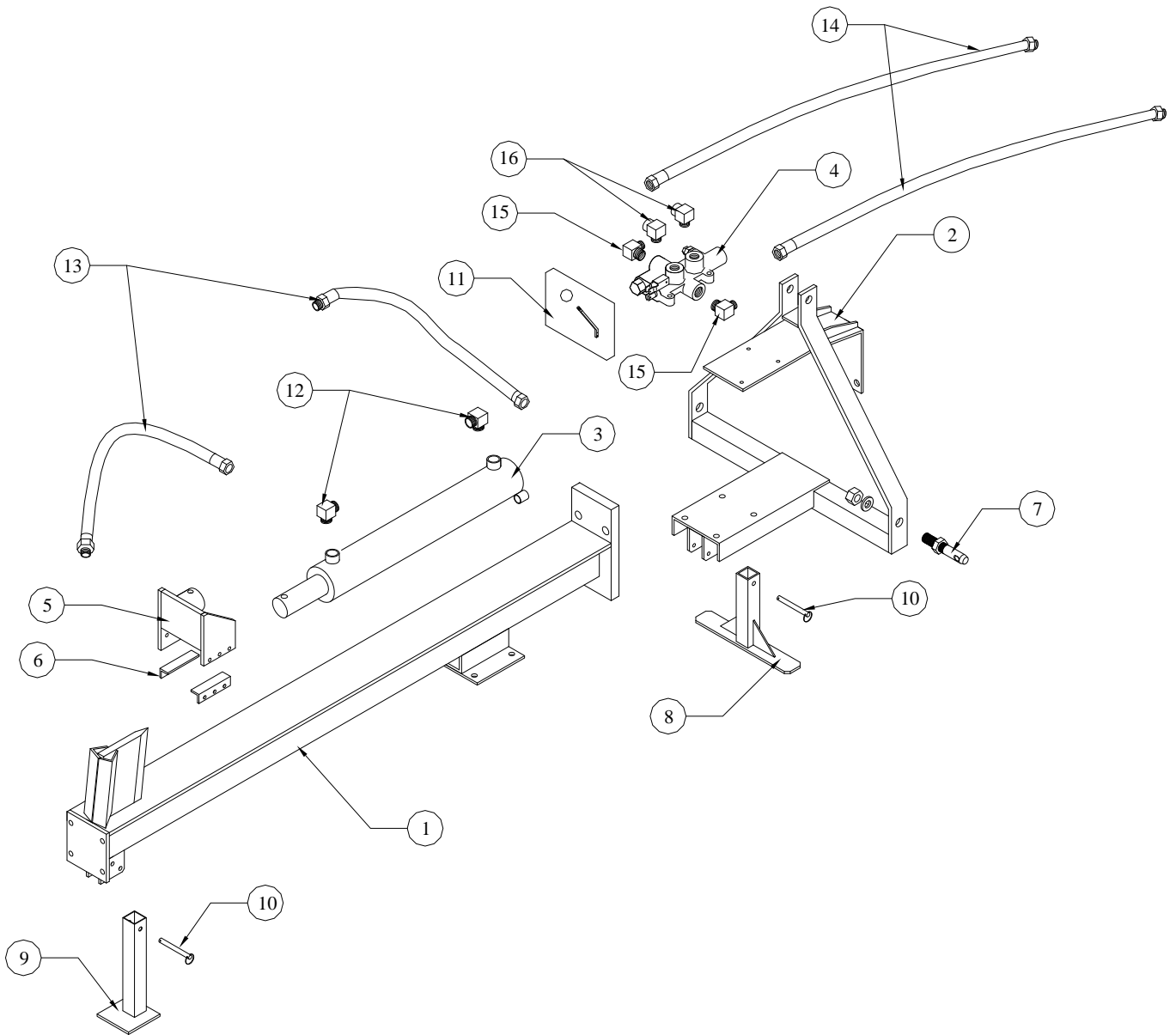

<u>Key</u>	<u>Part No.</u>	<u>Description</u>	<u>Key</u>	<u>Part No.</u>	<u>Description</u>
1	51694	Main Beam Assembly	51650		Decal, Danger Stop Engine
2	51705	3-Point Mount	51651		Decal, Danger Blade Hazard
3	51703	3 ½"Hyd. Cylinder	51652		Decal, Danger High Pressure
4	51613	Hyd. Control Valve	51654		Decal, Caution Only Splitting
5	51696	Pusher Block Assembly	51655		Decal, Warning Safety Pin
6	51697	Bracket, Push Block	51656		Decal, Caution Safety Chain
7	85024	Lift Arm Pin	51657		Decal, Forward/Reverse
8	51706	Kick Stand, front	51659		Decal, Warning No Children
9	82528	Kick Stand, rear	51660		Decal, Caution Read Manual
10	3121321	Detent Pin	51661		Decal, Warning Flying Wood
11	51675A	Handle Kit	51663		Decal, Do's/Do Not's
12	51639	Fitting, 90° ½ FP-1/2 MP	51664		Decal, Warning Crush Haz
13	51700	Hyd. Hose, 18"	51665		Decal, Warning Operator 10'
14	51708	Hyd. Hose, 36"	51668		Decal, Powertek 12 x 12 Black
15	51641	Fitting, 90° 3/4 MP - ½ MJIC	51649		Decal, Danger Beam Heavy
16	51671	Fitting, 90° 1/2 MJIC - 1/2MP			

9-20-07

## **GENERAL DESCRIPTION**

Read carefully before attempting to install, operate or service the **POWERTEK LOG SPLITTER**. Retain this information for future references.

Your **POWERTEK LOG SPLITTER** is American made and constructed of the best material available to do the job. Your safety has been considered in every feature and component of your **POWERTEK LOG SPLITTER**.

Your tractor supplies high-pressure oil to the cylinder by way of the control valve and high-pressure hoses. When the control valve is moved to the forward extend position, oil is allowed to flow through the hoses to the rear of the cylinder which, in turn, forces the ram to extend outward toward the wedge. When the control lever is reversed and put in the retract position, the direction of the oil flow is changed and the high-pressure oil is forced into the front of the cylinder, there by retracting the ram. A safety relief valve is preset at the factory to protect the hydraulic system from excessive pressures.

## **LOG SPLITTER PREPARATION PROCEDURE**

### **THE FOLLOWING ITEMS SHOULD BE ACCOMPLISHED AND CHECKED BEFORE MACHINE OPERATION:**

1. Splitter should be in a level position and used only out-of-doors, not in an enclosed area.
2. Make sure all connections, lines and hoses are tight and not damaged before filling with fluids.
3. Move control lever to the forward extend position and let ram move to the fully extended position. Reverse control lever and let ram move to its full reverse position. Check oil level. Cycle unit forward. Hold valve in forward position until you hear relief valve. Do the same in retract position to remove air from system. Do a final oil level check. Your **POWERTEK LOG SPLITTER** is now ready for use.



## GENERAL SAFETY INFORMATION

### 1. TRAINING

- A. Read and understand the Operation & Maintenance Manual and all safety instructions before attempting to use this log splitter.
- B. Do not allow anyone to operate log splitter who has not read the Operation & Maintenance Manual and safety instructions or has not been instructed for safe use of the log splitter.
- C. Never allow children or untrained adults to operate this machine.
- D. Most accidents occur when more than one (1) person operates the log splitter at any time. If a helper is assisting in providing logs to be split, never activate controls until the helper is clear of the work area. Only one person is to operate the log splitter at one time.
- E. Never allow anyone to ride on the log splitter.
- F. Never transport cargo on the log splitter.
- G. Extremely high fluid pressures are developed in hydraulic log splitters. Pressurized hydraulic fluid escaping through a pinhole opening can puncture skin and cause severe injury. Therefore, the following instructions should be heeded at all times:
  - (1) Do not operate with frayed, kinked, cracked or damaged hoses, fittings or tubing.
  - (2) Stop the engine and relieve hydraulic system pressure before changing or adjusting fittings, hoses, and tubing or other system components.
  - (3) Do not adjust the pressure settings of the pump or valve.
  - (4) Do not check for leaks with your hands. Leaks can be located by passing cardboard or wood over suspected area. Look for discoloration. If injured by escaping fluid, see a Doctor at once. Serious infection can develop if proper medical treatment is not administered immediately.
- H. The log splitter should be used only for splitting firewood and should be split only in the direction of the grain (not across the diameter of log).
- I. Keep the operator zone and adjacent area clear to ensure safe, secure footing as shown below.

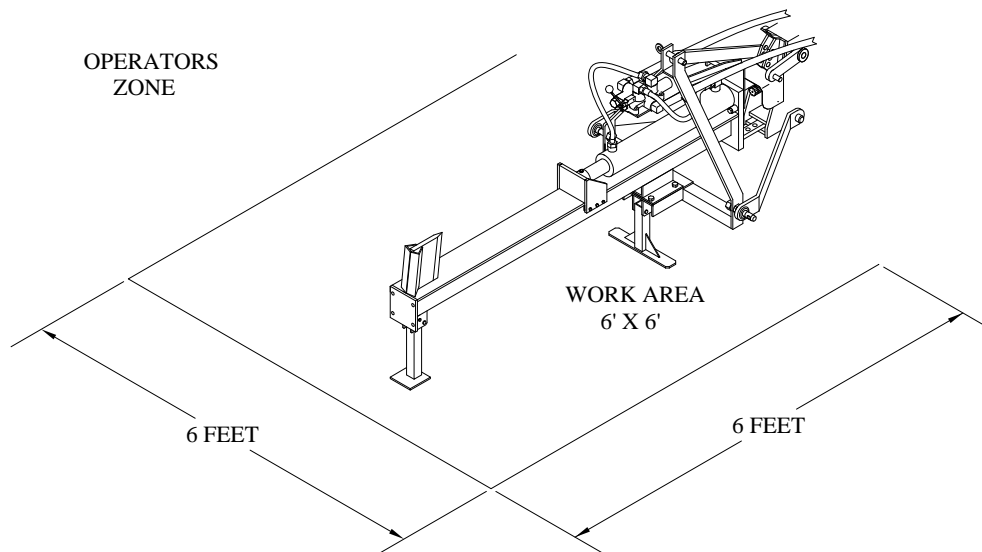

## **GENERAL SAFETY INFORMATION (CONTINUED)**

### **2. PREPARATION**

- A. Be thoroughly familiar with all controls and with the proper use of the log splitter.
- B. Always wear safety shoes or heavy boots. (No sneakers).
- C. Always wear safety glasses or goggles with side shields and hearing protection when operating the log splitter.
- D. Wear safety gloves.
- E. Never wear jewelry, loose clothing or clothing with strings that might become entangled in moving or rotating parts of the log splitter.
- F. Make sure the log splitter is on a level surface. Block the wheels securely before operating the machine to prevent unintended movement. Use chocks or split wood in front and behind each wheel to block the log splitter.
- G. Always operate the log splitter from the indicated operator zone. (See diagram page 8).
- H. Logs to be split should be cut as squarely as possible.

### **4. OPERATION**

- A. Before starting this log splitter, read and understand this entire manual including the Do Be Careful and General Safety Instructions. Failure to follow these rules may result in serious injury to the operator or bystanders.
- B. Never leave the machine unattended with the power source operating.
- C. Never operate the machine when under the influence of alcohol, drugs or medication.
- D. The machine owner should instruct all operators in safe log splitter operation.
- E. Always operate the log splitter with all safety equipment in place and all controls properly adjusted for safe operation.
- F. Do not tamper with parts that may increase the speed recommended by the manufacturer.
- G. Always keep hands and feet clear of moving parts.
- H. Always shut off the power source while repairing or adjusting the splitter except as recommended by the manufacturer.
- I. When loading the log splitter, place your hands on the side of the log. Never place your hands or any part of your body between a log and any part of the splitter.
- J. Never attempt to split more than one (1) log at a time.
- K. When logs are not cut square, the longest portion of the log should be rotated down and placed at the wedge end.
- L. Use only your hands to operate the log splitter controls.
- M. Operate the log splitter using only one (1) operator. Only the operator should be within 6 ft. of the machine while log splitter is operating. (see diagram page 11)
- N. Read and follow all safety and warning decals.

**GENERAL SAFETY INFORMATION (CONTINUED)**

**6. LUBRICATION & OIL**

- 1. A written record should be kept to log hours of use.

<b>MAINTENANCE SCHEDULE</b>				
	Daily	Weekly	Monthly	Yearly or as Required
Check Hydraulic Oil	<b>X</b>			
Inspect Hoses	<b>X</b>			
Repair Damage Areas on Beam/Blade				<b>X</b>
Tighten all Bolts and Fittings				<b>X</b>
<b>Change Engine Oil as Recommended by Engine Manufacturer.</b>				

## 7. CONTROLS

### Ram control valve

**To extend ram**, pull control lever to extend as the decal indicates. Holding the lever in this position, ram will continue to travel forward to its fully extended position until either the lever is released or until the ram reaches its fully extended position.

**As a safety precaution**, when lever is released it will automatically move to the center hold position, and the ram will stop. To move the ram, push the lever in the same direction as you wish the ram to move.

**To retract ram**, reverse the position of the control lever to the retract position. The control lever handle will stay in the retract mode until the cylinder reaches the full retract position and then it will automatically center to the hold position. However, the cylinder may be stopped at any position during the retract cycle by manually putting the control lever in the center hold position.

Additional or replacement manuals may be obtained from your local PowerTek distributor. When log splitter is received, complete the following record.

**MODEL/SERIAL NUMBER:** \_\_\_\_\_

**DATE OF PURCHASE:** \_\_\_\_\_

**WHERE PURCHASED:** \_\_\_\_\_

Always mention the machine's model and serial number when ordering or writing about parts.

For convenience in ordering, parts are listed by part number, description and quantity. Always supply part number and complete description when ordering. When assemblies can be used, order them to save time assembling individual parts. Prior arrangements must be made before returning parts for warranty service. Service calls should be directed to Customer Service at 1-877-769-7835.

To insure correct and prompt shipment of parts, always provide the following information when ordering.

1. Quantity of each part wanted
2. Part number and description
3. Model and serial number of log splitter
4. Preferred method of shipment: by mail, UPS, or airfreight

## **STORAGE**

### **FOR SAFE STORAGE:**

- A. To prevent rusting, coat the areas where paint has been scraped with an oil based rust prohibitor. Do not use heavy oil or grease because this will cause premature wear. Wipe off coating before use.
- B. Store splitter with ram in fully retracted position.

## **WARRANTY INFORMATION**

Each new product is warranted against manufacturing defects in workmanship and/or materials under normal use and service for a period of 12 months from the date of delivery of the product to the original purchaser. PowerTek Inc.'s obligation under this warranty shall be limited to the replacement to the original purchaser of any part which, as delivered to the original purchase, and upon PowerTek Inc.'s examination, is shown to PowerTek Inc.'s satisfaction, to be defective due to faulty workmanship or materials at the factory.

This warranty does not apply to damage in transit, damage caused by user misuse, negligence, accident, normal wear, or alterations or repairs done outside the factory and/or authorized service stations as determined by PowerTek Inc.

All parts claimed to be defective must be returned to PowerTek Inc.'s factory for inspection, repair or replacement, with all transportation or mailing charges prepaid. It is the exclusive responsibility of the purchaser to bear the transportation or mailing charges on any warranty claim.

This warranty specifically excludes engines or batteries, which are warranted separately by their respective manufacturers, all claims for defective batteries, engines or engine parts must be made in accordance with the battery and /or engine manufacturer's warranty. This warranty also specifically excludes costs of regular maintenance and replacement of service items such as belts, hoses, blades, and similar items.

PowerTek Inc. reserves the right to make changes upon PowerTek Inc.'s products without imposing any obligation upon PowerTek Inc. to install the same on a product manufactured prior to the change.

PowerTek Inc. makes no other warranties, representations or promises other than those set forth herein. **PowerTek Inc. specifically disclaims any and all implied warranties of fitness for particular purpose and merchantability.**

The remedies available to a distributor, dealer, and/or purchaser in connection with PowerTek Inc.'s warranty are set forth above. In no event will PowerTek Inc. be liable for special, incidental or consequential damages.

### **POWERTEK INC. WARRANTY PROCEDURE**

- A. All requests for warranty must have approval from PowerTek Inc. and/or distributor before work starts, or the warranty claim will be denied.
- B. All requests for warranty must be made on an OPEI or equivalent warranty claim form. This form is available from PowerTek Inc. or an authorized PowerTek Inc. distributor or dealer on a no charge basis.
- C. It is the responsibility of the distributor or dealer to complete the form warranty claim and submit it to PowerTek Inc..
  1. The form must be filled out completely. Claims received without serial numbers, model numbers, replacement part numbers, purchase dates, repair dates, purchaser's correct address, signature or other information requested by PowerTek Inc. shall be denied.
  2. Warranty claims that are illegible will be returned without service. Please type or print in black ink.
  3. PowerTek Inc.'s warranty makes no allowance for the time spent to fill out the warranty claim. Any such claim will be denied.

**WARRANTY PROCEDURE (CONTINUED)**

4. All parts shall be retained and tagged for a period of 60 days or until credit is issued.
  5. The factory may request parts to be returned for examination or analysis. These parts shall be sent by prepaid freight to PowerTek Inc. Returns sent freight collect, without express, written permission from PowerTek Inc. shall not be accepted.
  6. It is the responsibility of the dealer to review the claim and to comply fully with all procedures set forth herein. Failure to do so shall result in the denial of the warranty claim.
- D. Any warranty payments by PowerTek Inc. will be paid by credit memo to the distributor, dealer.
- E. All warranty claims, which are denied, will be returned with a reason for denial.
- F. Labor Allowance.
1. The warranty labor rate is \$35.00 per hour.
  2. The actual time is divided into tenths of an hour. The warranty form should show the time to the nearest tenth of an hour.
  3. Labor credit is based on the actual time required only to make the repair.
- G. Items not covered by warranty.
1. Mileage and transportation costs of any kind. All warranty is "Bench Work" only. The warranty specifically states that any transportation charges in connection with a warranty repair is the exclusive responsibility of the purchaser.
  2. Postage, delivery, telephone calls or similar communications.
  3. Normal maintenance or adjustments. This includes set up and service.
  4. Battery, engine or engine parts. Warranty on batteries, engines, engine parts or other vendor parts is covered by the component manufacturer's warranty and must be handled by that component manufacturer's representative.
  5. Failure caused by neglect, normal wear, or abuse. PowerTek Inc. depends on its distributor and dealer network to accurately determine when such conditions occur.
  6. Any alteration of the original design of the unit or the use of unauthorized or non-PowerTek Inc. parts. Any claim submitted containing such unauthorized alteration repairs shall be rejected.
  7. Freight or transportation damage. All such damage is the responsibility of the carrier and any claim for damages must be made with the carrier.
  8. Compound or repeat warranties caused by negligent/improper repair.
  9. Any claim for warranty where the date of repair exceeds sixty (60) days from the submission of the warranty claim.
  10. Any claim for warranty on the entire unit.
  11. Warranty claims involving oils or fluids of any kind.
  12. Any warranty claims for leaking, punctured, blown, flat, or otherwise damaged tires on units that have been placed in service.
  13. Lost time, lost rentals, lost profits, or other economic loss due to warranty work.

***Voluntary cooperation with the entire warranty procedure will make the program work better for both the purchaser and PowerTek Inc.***