

**Model 825 & 825-H
Operation & Maintenance Manual**

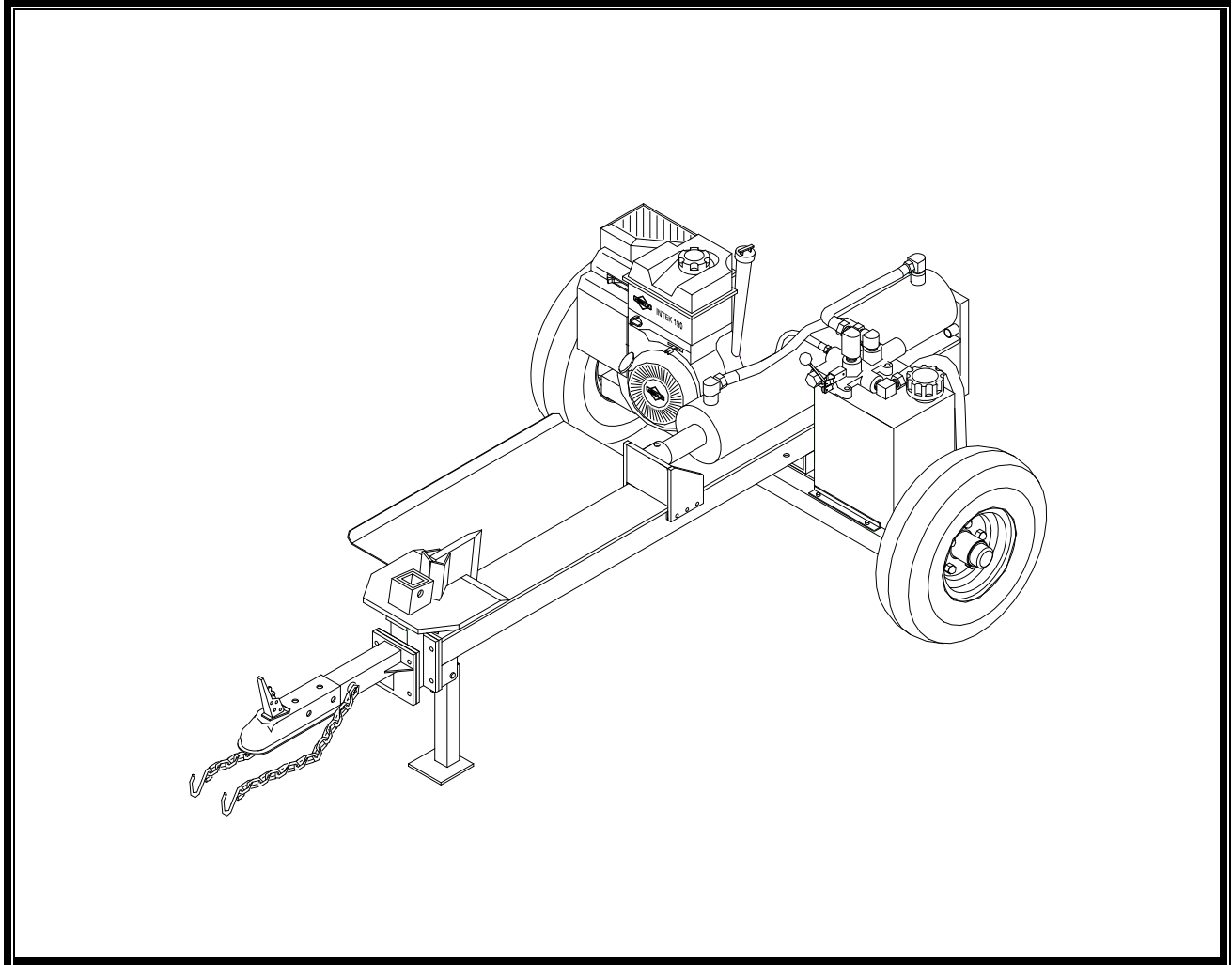

**PowerTek Inc.
P.O. Box 3
Lebanon, In. 46052
1-877-769-7835**

TABLE OF CONTENTS	POWERTEK
--------------------------	-----------------

- ASSEMBLY INSTRUCTIONS.....2, 3**
- DO BE CAREFUL.....4**
- PARTS BREAKDOWN.....5**
- PARTS LIST.....6**
- GETTING STARTED.....7**
 - GENERAL DESCRIPTION.....7
 - LOG SPLITTER PREPERATION.....7
- SAFETY.....8-10**
 - TRAINING.....8
 - PREPARATION.....9
 - TRANSPORTATION.....9
 - OPERATION.....9
 - MAINTENANCE AND STORAGE.....10
- LUBRICATION & FUEL.....11-12**
- MAINTENANCE SCHEDULE.....11**
- CONTROLS.....12**
- OWNERS INFORMATION.....13**
- WARRANTY.....14-15**

**PowerTek Inc.- LOG SPLITTERS
Shipped Partially Assembled**

**OWNER/OPERATOR'S INFORMATION FOR POWERTEK
LOG SPLITTER RESPONSIBILITY**

IT IS THE OPERATORS RESPONSIBILITY TO:

1. Carefully read and understand the entire Operation & Maintenance Manual along with the Assembly Instructions.
2. Be certain that all assembly procedures are followed as described in the following Assembly Instructions.
3. Fill equipment with the proper fluids before starting as described in the Operation & Maintenance Manual and the engine manufacturer's manual.
4. Operate the log splitter according to the safe operating procedures as spelled out in the Operation & Maintenance Manual and these Assembly Instructions.
5. Perform all required maintenance as directed in the Operation & Maintenance Manual, the engine manufacturer's manual, and these Assembly Instructions.

UNPACKING LOOSE PARTS:

Using care, remove the cover and sides from the pallet. The log splitter assemblies and parts are secured with bands. Carefully cut the bands. Remove all parts from the skid and layout in a clear unobstructed working area. Use the parts list below to assure all parts are accounted for. Do not discard packing material until assembly is complete to insure that no required parts are accidentally discarded.

Tools required: Adjustable wrench and socket set.

ASSEMBLY:

This unit must be assembled before use. Care must be taken in assembly to insure the proper functioning and reliability of the unit. Assembly must be done in a dry and clean area.

1. Attach tires to Motor Base Assembly (82523).
2. Carefully support Motor Base, then attach Main Beam (82529) with hardware provided.
3. Unit can now be balanced on Kickstand (82528)
4. Attach drawbar (82528) & Log Tray (51698) with hardware provided.
5. Connect all hoses and tighten all hardware.
6. Fill Hydraulic Reservoir with Dextron III Automatic Transmission Fluid. (Approximately 3 Gal.)
7. Fill Engine with Proper Amount and Type of Motor oil. See operation Manual for further details.
8. Start engine and cycle ram to full extent and return to fill cylinder. Refill Hydraulic Reservoir.

BEFORE EACH USE DO THE FOLLOWING:

1. Make sure all bolts, fittings, and hoses are tight. If fittings are not tight, log splitter will not function properly.
2. Make sure you have read the all safety and start up procedures in the Operation and Maintenance Manual.
3. Make sure that Dextron III or equivalent hydraulic oil is used in the hydraulic system before starting the engine.
4. Check for oil leaks on initial start-up. Repair any hydraulic lines, as necessary.
5. Double check oil levels in engine and hydraulic system before splitting your wood.
6. While towing, obey all local and state laws.
7. If towing over the road, make sure that the fuel shut off is in the off position on the engine gas tank.

SERVICE TIPS

1. To clean the hydraulic screens (drain tank before removing screen) remove the screen from the reservoir and clean in a petroleum-based solvent. Clean inside of tank, air-dry screen and replace in reservoir. Tighten.
2. To drain hydraulic tank, remove 1/2" x 15" hose from valve and drain the contents into a container. To drain cylinder, remove the 1/2" x 54" and 1/2" x 42" hose from the valve. Point hoses into a container and manually pull cylinder forward until all fluid is expelled. Re-attach hoses and tighten. Refill with fresh fluid. See page 11 of this Operation & Maintenance Manual for frequency of fluid change and type of fluid to be used. Dispose of all used fluids according to local, state and Federal environmental regulations.

**CAUTION**

DO NOT OPERATE THIS LOG SPLITTER UNTIL YOU HAVE AND UNDERSTAND THE OPERATING AND SAFETY INSTRUCTIONS. FAILURE TO READ AND FOLLOW OPERATING INSTRUCTIONS CAN RESULT IN SERIOUS INJURY OR DEATH TO YOURSELF AND/OR OTHERS

DO

- DO MAKE SURE THAT ANYONE WHO OPERATES THIS SPLITTER READS AND UNDERSTANDS ALL OPERATING INSTRUCTIONS AS TO ITS PROPER USE AND OPERATION AS WELL AS ALL SAFETY INSTRUCTIONS.
- DO KEEP YOUR WORK AREA CLEAN. DON'T LEAVE WOOD LAYING AROUND THAT YOU COULD STUMBLE OVER.
- DO KEEP HANDS AND FEET CLEAR OF SPLITTER BLADE AND OUT OF SPLITTER AREA WHILE UNIT IS IN OPERATION.
- DO WIPE UP SPILLED GAS RIGHT AWAY FROM THE ENGINE AND LOG SPLITTER BEFORE STARTING THE ENGINE.
- DO CHECK ENGINE OIL LEVEL AND HYDRAULIC OIL LEVEL BEFORE STARTING THE SPLITTER.
- DO USE THE UNIT ONLY TO SPLIT FIREWOOD LOGS. USE OF THE UNIT FOR ANY OTHER PURPOSE SHALL VOID THE WARRANTY.
- DO WEAR EYE PROTECTION AND PROTECTIVE CLOTHING, INCLUDING SAFETY SHOES AT ALL TIMES WHILE LOG SPLITTER IS IN OPERATION TO AVOID ANY HAZARD FROM FLYING WOOD.
- DO KEEP CHILDREN AND PETS AWAY FROM THE WORK AREA WHILE YOU ARE OPERATING THE LOG SPLITTER.
- DO SHUT OFF THE ENGINE IF YOU LEAVE THE LOG SPLITTER, EVEN FOR A SHORT PERIOD OF TIME.
- DO OPERATE LOG SPLITTER ON LEVEL SURFACE BLOCK WHEELS TO PREVENT UNINTENDED MOVEMENT.
- DO LET GO OF THE CONTROL LEVER AFTER IT IS PUSHED FORWARD. THE RAM WILL RETURN AUTOMATICALLY AT THE END OF THE STROKE. THE RAM CAN ALSO BE STOPPED AT ANY POINT IN ITS TRAVEL AND RETURNED.
- DO REMOVE BOTH HANDS FROM LOG BEFORE ACTIVATING CONTROL LEVER.
- DO BE SURE THE SPLITTER IS KEPT IN SOUND MECHANICAL CONDITION. PROPER CARE, MAINTENANCE AND FOLLOWING ALL OPERATING AND SAFETY INSTRUCTIONS WILL PROVIDE YOU WITH MANY YEARS OF TROUBLE-FREE AND SAFE OPERATION.

**DO
BE CAREFUL
SAFETY FIRST !!!**

DO NOT

- DO NOT ALLOW ANYONE TO OPERATE THE LOG SPLITTER UNTIL THEY HAVE READ AND UNDERSTAND THE OPERATING INSTRUCTIONS AND SAFETY INSTRUCTIONS.
- DO NOT ALLOW ANYONE UNDER 18 YEARS OF AGE TO OPERATE THE LOG SPLITTER
- DO NOT OPERATE THE LOG SPLITTER IN THE VICINITY OR NEAR CHILDREN OR PETS.
- DO NOT WEAR JEWELRY, LOOSE-FITTING CLOTHING OR CLOTHING WITH DRAWSTRINGS WHEN OPERATING THE LOG SPLITTER, AS SUCH JEWELRY OR CLOTHING MAY BECOME ENTANGLED IN MOVING PARTS OF LOG SPLITTER.
- DO NOT OPERATE RAM CONTROL LEVER IN ANY WAY OTHER THAN BY HAND.
- DO NOT LEAVE THE LOG SPLITTER UNATTENDED WITH THE ENGINE RUNNING.
- DO NOT OPERATE THE LOG SPLITTER BEYOND THE CAPABILITIES AS OUTLINED IN THE OWNERS MANUAL AND OPERATING INSTRUCTIONS.
- DO NOT STEP OVER THE LOG SPLITTER WHEN RUNNING. WALK AROUND THE LOG SPLITTER TO GET TO THE OTHER SIDE.
- DO NOT STRADDLE THE LOG SPLITTER WHEN OPERATING.
- DO NOT LET ANYONE STAND NEAR THE WEDGE WHEN SPLITTING WOOD, AS FLYING WOOD MAY BE HAZARDOUS.
- DO NOT STAND ON SLIPPERY, WET, MUDDY OR ICY SURFACES WHEN OPERATING THE LOG SPLITTER. OPERATE ONLY WHEN OPERATOR ZONE IS CLEAR FOR SAFE, SECURE FOOTING.
- DO NOT OPERATE THE LOG SPLITTER INSIDE A BUILDING OR CLOSED IN AREA THAT DOES NOT HAVE ADEQUATE VENTILATION.
- DO NOT REFUEL WHILE ENGINE IS ON OR HOT, WHILE OPERATOR IS SMOKING OR WHILE UNIT IS NEAR OPEN FLAME.
- DO NOT OPERATE THE LOG SPLITTER IF IT NEEDS REPAIRS OR MAINTENANCE.
- DO NOT MAKE ANY MODIFICATIONS, ALTERATIONS OR CHANGES TO THE ORIGINAL CONFIGURATION OF THE LOG SPLITTER. THIS MAY CAUSE INJURY AND SHALL VOID THE WARRANTY.
- DO NOT EVER LOAD A LOG BY HOLDING ONTO BOTH ENDS OF THE LOG.
- DO NOT PLACE YOUR HANDS BETWEEN THE RAM AND THE LOG, BETWEEN THE LOG AND THE WEDGE, OR BETWEEN TWO PIECES OF LOG ON THE FRAME. SEE OWNERS MANUAL FOR PROPER LOADING PROCEDURES.
- DO NOT SERVICE OR REPAIR LOG SPLITTER WITHOUT REMOVING THE SPARK PLUG WIRE.
- DO NOT ALLOW ANYONE EXCEPT THE OPERATOR WITHIN 10 FEET OF LOG SPLITTER DURING OPERATION.
- DO NOT OPERATE UNIT WITH HYDRAULIC FLUID LEAK. CHECK HYDRAULIC LINE BEFORE OPERATING LOG SPLITTER, AND REPAIR OR REPLACE AS NECESSARY.

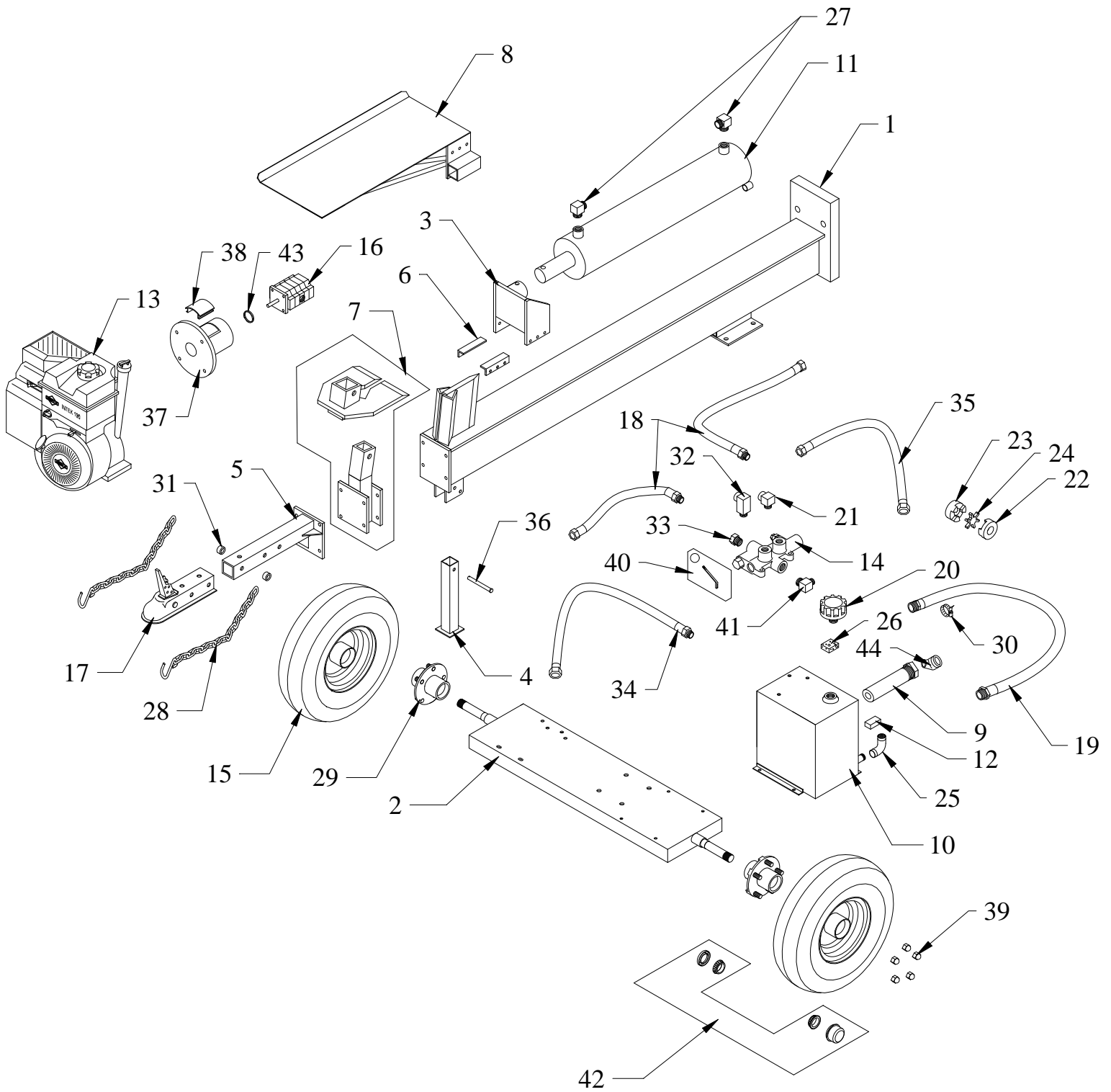

3-13-06

<u>Key</u>	<u>Part No.</u>	<u>Description</u>	<u>Key</u>	<u>Part No.</u>	<u>Description</u>
1	82529	Main Beam Assembly	51649		Decal, Danger Beam Heavy
2	82523	Motor Base	51650		Decal, Danger Stop Engine
3	82530	Pusher Block Assembly	51651		Decal, Danger Blade Hazard
4	82528	Kick Stand	51652		Decal, Danger High Pressure
5	82525	Drawbar Assembly	51654		Decal, Caution Only Splitting
6	51697	Bracket, Push Block	51655		Decal, Warning Safety Pin
7	82527A	4Way Wedge (Optional)	51656		Decal, Caution Safety Chain
8	51698	Log Tray	51657		Decal, Forward/Reverse
9	51630	Strainer	51659		Decal, Warning No Children
10	51605	Hydraulic Tank	51660		Decal, Caution Read Manual
11	82510	5" Hyd. Cylinder	51661		Decal, Warning Flying Wood
12	51643	Magnet	51663		Decal, Do's/Do Not's
13	86022	Engine, 8HP Intek	51664		Decal, Warning Crush Haz
	86020	Engine, 8HP Honda	51665		Decal, Warning Operator 10'
14	51613	Hyd. Control Valve	51668		Decal, Powertek 2 x 12 Black
15	51611	Wheel Assembly			
16	82507	Hydraulic Pump, 8 HP			
17	51601	2" Ball Coupler			
18	51700	Hose, Valve Return, 18"			
19	82506	Hose, Pump Supply			
20	51620	Hyd. Tank Cap			
21	51671	Fitting, 90° 1/2MJIC-1/2MP			
22	82512A	Coupling Jaw-3/4"			
23	82512B	Coupling Jaw-1/2"			
24	82512C	Coupling Spider			
25	51621	1/2"-90° Pipe Elbow			
26	51677	Foam, Hyd. Tank Cap			
27	51639	Fitting, 90° 1/2FP-1/2MP			
28	51624	Safety Chain W/Hooks			
29	16321	Wheel Hub			
30	1251401	1 1/4" Hose Clamp			
31	51625	Spacer, Safety Chain			
32	51671LL	Fitting, 90° 1/2MJIC-1/2MP			
33	51699	Fitting, 3/4MP to 1/2 FP			
34	72665	Hose, Valve Supply, 28"			
35	51619	Hose, Valve Return, 15"			
36	3121321	Detent Pin			
37	82508	Pump Mount			
38	82509	Pump Mount Shield			
39	5001002	Lug Nut			
40	51675A	Handle Kit			
41	51641	Fitting, 90° 3/4MP to 1/2MJIC			
42	51667	Bearing Kit			
43	82513	Adapter Ring, 8HP Pump Mount			
44	46102	3/4-45° Street Elbow			
	825102	Seal Kit 5" Cylinder, s/n 61683 thru 61931			
	825103	Seal Kit 5" Cylinder, s/n 61932/up			

2-22-08

GENERAL DESCRIPTION

Read carefully before attempting to install, operate or service the **POWERTEK LOG SPLITTER**. Retain this information for future references.

Your **POWERTEK LOG SPLITTER** is American made and constructed of the best material available to do the job. Your safety has been considered in every feature and component of your **POWERTEK LOG SPLITTER**.

The gasoline engine operates a pump, which supplies high-pressure oil to the cylinder by way of the control valve and high-pressure hoses. When the control valve is moved to the forward extend position, oil is allowed to flow through the hoses to the rear of the cylinder which, in turn, forces the ram to extend outward toward the wedge. When the control lever is reversed and put in the retract position, the direction of the oil flow is changed and the high-pressure oil is forced into the front of the cylinder, there by retracting the ram. A large reservoir stores and cools the hydraulic oil and incorporates a high-density screen to filter out any foreign particles and, therefore greatly wends the life of your **POWERTEK LOG SPLITTER**. A safety relief valve is preset at the factory to protect the hydraulic system from excessive pressures.

LOG SPLITTER PREPARATION PROCEDURE

THE FOLLOWING ITEMS SHOULD BE ACCOMPLISHED AND CHECKED BEFORE

MACHINE OPERATION:

1. Splitter should be in a level position and used only out-of-doors, not in an enclosed area.
2. Make sure all connections, lines and hoses are tight and not damaged before filling with fluids.
3. Oil should be placed in the engine crankcase according to the instructions in the engine manufacturer's instruction manual. Gasoline is then put into the gas tank on the engine and standard operating procedures should be followed according to the engine manual. **DO NOT** start engine until hydraulic oil has been added to the hydraulic system.
4. When filling the hydraulic system of the splitter with fluid, add Dextron II or III automatic transmission fluid to the hydraulic oil reservoir until it is filled to within 1" from the top. Replace reservoir cap. A light hydraulic oil can be also be used, such as Mobil DTE 13M.
5. Pull engine over 3 or 4 times with stop switch in off position. Now place stop switch in run position and start engine. Move control lever to the forward extend position and let ram move 1/2 its length. Stop engine. Add oil to reservoir to within 1" of top.
6. Start engine. Move control lever to the forward extend position and let ram move to the fully extended position. Reverse control lever and let ram move to its full reverse position. Stop engine. Check oil level. Add oil to within 1" of top if needed. Cycle unit forwards and backwards 5 to 10 times or until cylinder stops jumping. Do a final oil level check. Your **POWERTEK LOG SPLITTER** is now ready for use.

GENERAL SAFETY INFORMATION

1. TRAINING

- A. Read and understand the Operation & Maintenance Manual and all safety instructions before attempting to use this log splitter.
- B. Do not allow anyone to operate log splitter who has not read the Operation & Maintenance Manual and safety instructions or has not been instructed for safe use of the log splitter.
- C. Never allow children or untrained adults to operate this machine.
- D. Most accidents occur when more than one (1) person operates the log splitter at any time. If a helper is assisting in providing logs to be split, never activate controls until the helper is clear of the work area. Only one person is to operate the log splitter at one time.
- E. Never allow anyone to ride on the log splitter.
- F. Never transport cargo on the log splitter.
- G. Extremely high fluid pressures are developed in hydraulic log splitters. Pressurized hydraulic fluid escaping through a pinhole opening can puncture skin and cause severe injury. Therefore, the following instructions should be heeded at all times:
 - (1) Do not operate with frayed, kinked, cracked or damaged hoses, fittings or tubing.
 - (2) Stop the engine and relieve hydraulic system pressure before changing or adjusting fittings, hoses, and tubing or other system components.
 - (3) Do not adjust the pressure settings of the pump or valve.
 - (4) Do not check for leaks with your hands. Leaks can be located by passing cardboard or wood over suspected area. Look for discoloration. If injured by escaping fluid, see a Doctor at once. Serious infection can develop if proper medical treatment is not administered immediately.
- H. Your log splitter is equipped with an internal combustion engine and if it is used near any unimproved forest, brush or grass land, the engine exhaust must be equipped with a spark arrester which meets all applicable local, state and federal codes. These may be purchased from the engine manufacturer. Take appropriate fire fighting equipment with you.
- I. The log splitter should be used only for splitting firewood and should be split only in the direction of the grain (not across the diameter of log).
- J. Keep the operator zone and adjacent area clear to ensure safe, secure footing, as shown below.

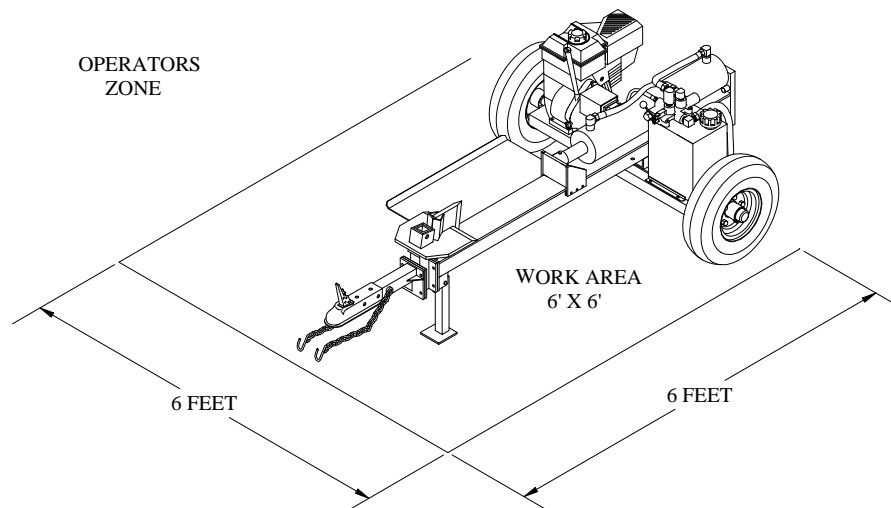

GENERAL SAFETY INFORMATION (CONTINUED)

2. PREPARATION

- A. Be thoroughly familiar with all controls and with the proper use of the log splitter.
- B. Always wear safety shoes or heavy boots. (No sneakers).
- C. Always wear safety glasses or goggles with side shields and hearing protection when operating the log splitter.
- D. Wear safety gloves.
- E. Never wear jewelry, loose clothing or clothing with strings that might become entangled in moving or rotating parts of the log splitter.
- F. Make sure the log splitter is on a level surface. Block the wheels securely before operating the machine to prevent unintended movement. Use chocks or split wood in front and behind each wheel to block the log splitter.
- G. Always operate the log splitter from the indicated operator zone. (See diagram page 10).
- H. Logs to be split should be cut as squarely as possible.
- I. Handle fuel with care; it is highly flammable.
 - 1. Use an approved fuel container.
 - 2. Never add fuel to a running or hot engine.
 - 3. Fill fuel tank outdoors with extreme care. Never fill fuel tank indoors.
 - 4. Replace gasoline cap securely and clean up spilled fuel.

3. SAFE TRANSPORTATION OF LOG SPLITTER

When transporting the log splitter over the road, fuel coming from the gas tank should be shut off (if possible) by means of the shut-off valve located under the gas tank. Some engines do not have a gas shut off.

4. OPERATION

- A. Before starting this log splitter, read and understand this entire manual including the Do Be Careful and General Safety Instructions. Failure to follow these rules may result in serious injury to the operator or bystanders.
- B. Never leave the machine unattended with the power source operating.
- C. Never operate the machine when under the influence of alcohol, drugs or medication.
- D. The machine owner should instruct all operators in safe log splitter operation.
- E. Always operate the log splitter with all safety equipment in place and all controls properly adjusted for safe operation.
- F. Do not tamper with parts that may increase the speed recommended by the manufacturer.
- G. Always keep hands and feet clear of moving parts.
- H. Always shut off the power source while repairing or adjusting the splitter except as recommended by the manufacturer.

GENERAL SAFETY INFORMATION (CONTINUED)

4. OPERATION (CONTINUED)

- I. Do not run engine in an enclosed area. Exhaust gas contains carbon monoxide, an odorless and deadly poisonous gas.
- J. When loading the log splitter, place your hands on the sides of the log. Never place your hands or any part of your body between a log and any part of the log splitter.
- K. Never attempt to split more than one (1) log at a time.
- L. When the logs are not cut square, the longest portion of the log should be rotated down and placed at the wedge end.
- M. Use only your hand to operate the log splitter controls.
- N. Operate the log splitter using only one operator. Only the operator should be within 10 ft of the machine while the log splitter is operating. (See diagram page10)
- O. Read and follow all safety and warning decals.
- P. On vertical models keep hands away from moving blade.
- Q. On vertical models maintain control of the beam when raising or lowering the beam.
- R. On vertical models make sure beam safety pin is installed when unit is in the vertical or splitting mode or the horizontal-towing mode.
- S. Do not refuel the engine until it has cooled for several minutes.

5. MAINTENANCE AND STORAGE

Note: (For proper maintenance keep a written record of hour use and maintenance).

- A. Always shut off engine. While repairing or adjusting log splitter except as recommended by engine manufacturer.
- B. Clean debris and chaff from engine cylinder, cylinder head fins, blower housing, screen and muffler areas. If the engine is equipped with a spark arrester muffler, clean and inspect it regularly (follow engine manufacturer service instructions). Replace, if damaged.
- C. Never store log splitter with fuel in the tank inside a building where fumes might reach an open flame or spark. Allow the engine to cool and drain all fuel from the fuel tank before storing in any enclosed area.
- D. Clear debris from movable parts, but only when the power source is shut off.
- E. To prevent accidental starting, remove spark plug cable from the spark plug.
- F. Check to be sure all nuts and bolts are tight to assure the log splitter is in safe working condition.
- G. Check engine oil level and hydraulic oil level.
- H. Check brass wearstrips on slide plate. All models have wearstrips. Replace when needed.

GENERAL SAFETY INFORMATION (CONTINUED)

6. LUBRICATION, OIL & FUEL

1. A written record should be kept to log hours of use.
2. Motor oil in the crankcase of the engine and fuel specifications should be followed from the engine manufactures manual supplied with the unit.
3. Dextron II or III automatic transmission fluid is recommended for the hydraulic system.
4. After every 5 hours of operation the unit should be stopped and, with the ram in a retracted position, the hydraulic oil level should be checked. It should be 1” to 2” from the top of the filler cap hole.
5. If a considerable amount of trailering or over the road use is necessary, the wheel bearings should be packed with wheel bearing grease every 2000 miles or once a year, whichever occurs sooner.
6. After every 50 hours of operation the motor oil should be changed and the air filter should be cleaned, and changed if necessary.
7. Hydraulic oil should be changed at least once a year, but more frequently for heavy duty, or commercial usage. In extremely dusty or dirty conditions the oil should be changed more frequently to meet these unusual conditions.

MAINTENANCE SCHEDULE				
	Daily	Weekly	Monthly	Yearly or as Required
Check Engine Oil	X			
Check Hydraulic Oil	X			
Inspect Hoses	X			
Inspect/Clean Engine Cooling Fins	X			
Check Machine Tire Pressure	X			
Check Trailer Hitch and Safety Chains	X			
Clean/Service Engine Air Filter		X		
Check Brass Wearstrips			X	
Repair Damage Areas on Beam/Blade				X
Check and Gap Spark Plugs				X
Replace Hydraulic Oil and Clean Filter				X
Check/Service Wheel Bearings				X
Tighten all Bolts and Fittings				X
Change Engine Oil as Recommended by Engine Manufacturer.				

6. LUBRICATION OIL & FUEL (CONTINUED)

To change the hydraulic oil, please see service tips page 3, # 2. Stop engine. Drain oil from reservoir. When oil from reservoir has emptied out, remove front and rear hose and manually push ram in toward cylinder. This motion will evacuate the remainder of the hydraulic oil from the system. Replace hose. Refill with oil.

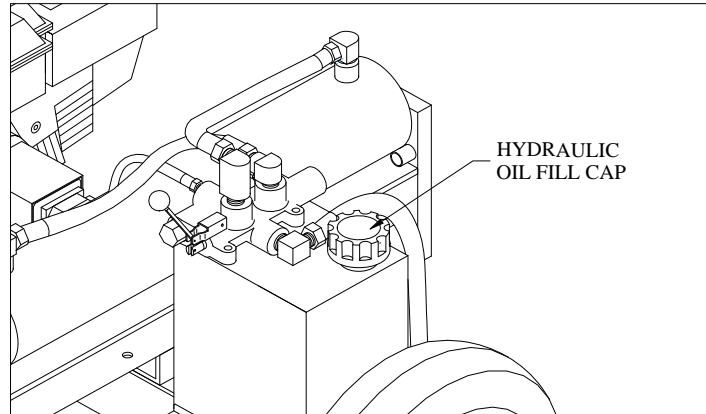

7. CONTROLS

Engine run-stop switch

To shut off engine, turn switch to stop position. Before attempting to start engine, be sure switch is in run position.

Engine choke control

If engine does not start initially set choke control to full on position. When engine starts, set choke control to normal operating position.

Engine recoil starter handle

It takes short, steady pulls in rapid succession to start engine. Do not jerk the starter handle. Do not release the starter handle when fully extended and let it snap back.

Ram control valve

To extend ram, pull control lever to extend as the decal indicates. Holding the lever in this position, ram will continue to travel forward to its fully extended position until either the lever is released or until the ram reaches its fully extended position.

As a safety precaution, when lever is released it will automatically move to the center hold position, and the ram will stop. This lever feature is referred to as a "deadman" control switch. To move the ram, push the lever in the same direction as you wish the ram to move.

To retract ram, reverse the position of the control lever to the retract position. The control lever handle will stay in the retract mode until the cylinder reaches the full retract position and then it will automatically center to the hold position. However, the cylinder may be stopped at any position during the retract cycle by manually putting the control lever in the center hold position.

OWNERS INFORMATION

POWERTEK

Additional or replacement manuals may be obtained from your local PowerTek distributor. When log splitter is received, complete the following record.

MODEL/SERIAL NUMBER: _____

DATE OF PURCHASE: _____

WHERE PURCHASED: _____

Always mention the machine's model and serial number when ordering or writing about parts.

For convenience in ordering, parts are listed by part number, description and quantity. Always supply part number and complete description when ordering. When assemblies can be used, order them to save time assembling individual parts. Prior arrangements must be made before returning parts for warranty service. Service calls should be directed to Customer Service at 1-877-769-7835.

To insure correct and prompt shipment of parts, always provide the following information when ordering.

1. Quantity of each part wanted
2. Part number and description
3. Model and serial number of log splitter
4. Preferred method of shipment: by mail, UPS, or airfreight

STORAGE

FOR SAFE STORAGE:

- A. Clean dirt and debris from engine and log splitter
- B. To prevent rusting, coat the areas where paint has been scraped with an oil based rust prohibitor. Do not use heavy oil or grease because this will cause premature wear. Wipe off coating before use.
- C. Store splitter with ram in fully retracted position. It is required that you drain the gas from tank and run engine until carburetor gas is exhausted before storing the log splitter.

WARRANTY INFORMATION

Each new product is warranted against manufacturing defects in workmanship and/or materials under normal use and service for a period of 12 months from the date of delivery of the product to the original purchaser. PowerTek Inc.'s obligation under this warranty shall be limited to the replacement to the original purchaser of any part which, as delivered to the original purchase, and upon PowerTek Inc.'s examination, is shown to PowerTek Inc.'s satisfaction, to be defective due to faulty workmanship or materials at the factory.

This warranty does not apply to damage in transit, damage caused by user misuse, negligence, accident, normal wear, or alterations or repairs done outside the factory and/or authorized service stations as determined by PowerTek Inc.

All parts claimed to be defective must be returned to PowerTek Inc.'s factory for inspection, repair or replacement, with all transportation or mailing charges prepaid. It is the exclusive responsibility of the purchaser to bear the transportation or mailing charges on any warranty claim.

This warranty specifically excludes engines or batteries, which are warranted separately by their respective manufacturers, all claims for defective batteries, engines or engine parts must be made in accordance with the battery and /or engine manufacturer's warranty. This warranty also specifically excludes costs of regular maintenance and replacement of service items such as belts, hoses, blades, and similar items.

PowerTek Inc. reserves the right to make changes upon PowerTek Inc.'s products without imposing any obligation upon PowerTek Inc. to install the same on a product manufactured prior to the change.

PowerTek Inc. makes no other warranties, representations or promises other than those set forth herein. **PowerTek Inc. specifically disclaims any and all implied warranties of fitness for particular purpose and merchantability.**

The remedies available to a distributor, dealer, and/or purchaser in connection with PowerTek Inc.'s warranty are set forth above. In no event will PowerTek Inc. be liable for special, incidental or consequential damages.

POWERTEK INC. WARRANTY PROCEDURE

- A. All requests for warranty must have approval from PowerTek Inc. and/or distributor before work starts, or the warranty claim will be denied.
- B. All requests for warranty must be made on an OPEI or equivalent warranty claim form. This form is available from PowerTek Inc. or an authorized PowerTek Inc. distributor or dealer on a no charge basis.
- C. It is the responsibility of the distributor or dealer to complete the form warranty claim and submit it to PowerTek Inc..
 1. The form must be filled out completely. Claims received without serial numbers, model numbers, replacement part numbers, purchase dates, repair dates, purchaser's correct address, signature or other information requested by PowerTek Inc. shall be denied.
 2. Warranty claims that are illegible will be returned without service. Please type or print in black ink.
 3. PowerTek Inc.'s warranty makes no allowance for the time spent to fill out the warranty claim. Any such claim will be denied.

WARRANTY PROCEDURE (CONTINUED)

4. All parts shall be retained and tagged for a period of 60 days or until credit is issued.
 5. The factory may request parts to be returned for examination or analysis. These parts shall be sent by prepaid freight to PowerTek Inc. Returns sent freight collect, without express, written permission from PowerTek Inc. shall not be accepted.
 6. It is the responsibility of the dealer to review the claim and to comply fully with all procedures set forth herein. Failure to do so shall result in the denial of the warranty claim.
- D. Any warranty payments by PowerTek Inc. will be paid by credit memo to the distributor, dealer.
- E. All warranty claims, which are denied, will be returned with a reason for denial.
- F. Labor Allowance.
1. The warranty labor rate is \$35.00 per hour.
 2. The actual time is divided into tenths of an hour. The warranty form should show the time to the nearest tenth of an hour.
 3. Labor credit is based on the actual time required only to make the repair.
- G. Items not covered by warranty.
1. Mileage and transportation costs of any kind. All warranty is "Bench Work" only. The warranty specifically states that any transportation charges in connection with a warranty repair is the exclusive responsibility of the purchaser.
 2. Postage, delivery, telephone calls or similar communications.
 3. Normal maintenance or adjustments. This includes set up and service.
 4. Battery, engine or engine parts. Warranty on batteries, engines, engine parts or other vendor parts is covered by the component manufacturer's warranty and must be handled by that component manufacturer's representative.
 5. Failure caused by neglect, normal wear, or abuse. PowerTek Inc. depends on its distributor and dealer network to accurately determine when such conditions occur.
 6. Any alteration of the original design of the unit or the use of unauthorized or non-PowerTek Inc. parts. Any claim submitted containing such unauthorized alteration repairs shall be rejected.
 7. Freight or transportation damage. All such damage is the responsibility of the carrier and any claim for damages must be made with the carrier.
 8. Compound or repeat warranties caused by negligent/improper repair.
 9. Any claim for warranty where the date of repair exceeds sixty (60) days from the submission of the warranty claim.
 10. Any claim for warranty on the entire unit.
 11. Warranty claims involving oils or fluids of any kind.
 12. Any warranty claims for leaking, punctured, blown, flat, or otherwise damaged tires on units that have been placed in service.
 13. Lost time, lost rentals, lost profits, or other economic loss due to warranty work.

Voluntary cooperation with the entire warranty procedure will make the program work better for both the purchaser and PowerTek Inc.